

ALL PROPERTIES ARE PLOTTED FROM DEEDS OF RECORD, RECORDED SUBDIVISION OR LOT PLANS, OR FROM FIELD SURVEY. PROPERTY LINES WERE SURVEYED ONLY WHEN DETERMINED NECESSARY BY THE PROFESSIONAL LAND SURVEYOR RESPONSIBLE FOR THE PROJECT. PROPERTY LINES NOT ESTABLISHED BY FIELD SURVEY WERE PLOTTED BASED ON EXISTING TOPOGRAPHICAL FEATURES AND LIMITED FIELD DATA.

THIS PLAN IS NOT TO BE SUBSTITUTED FOR A BOUNDARY SURVEY

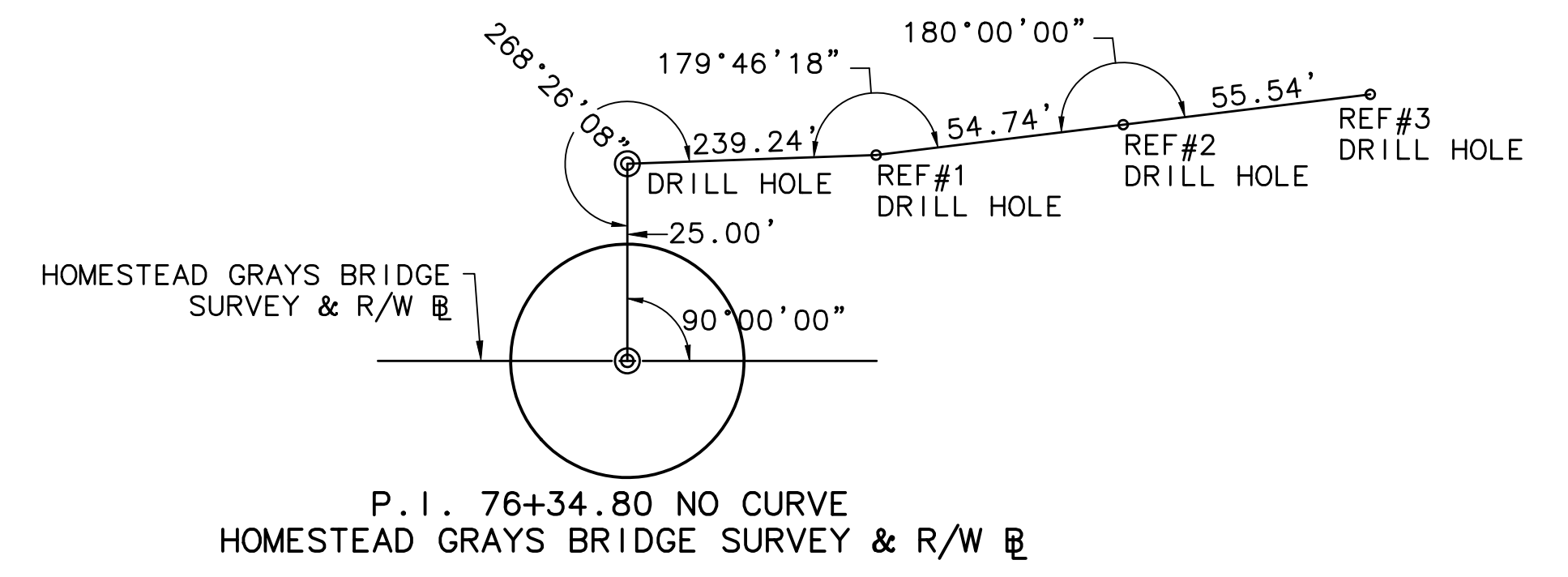

P. I. 76+34.80 NO CURVE
HOMESTEAD GRAYS BRIDGE SURVEY & R/W

CONTINUED ON SHEET 7 OF 10

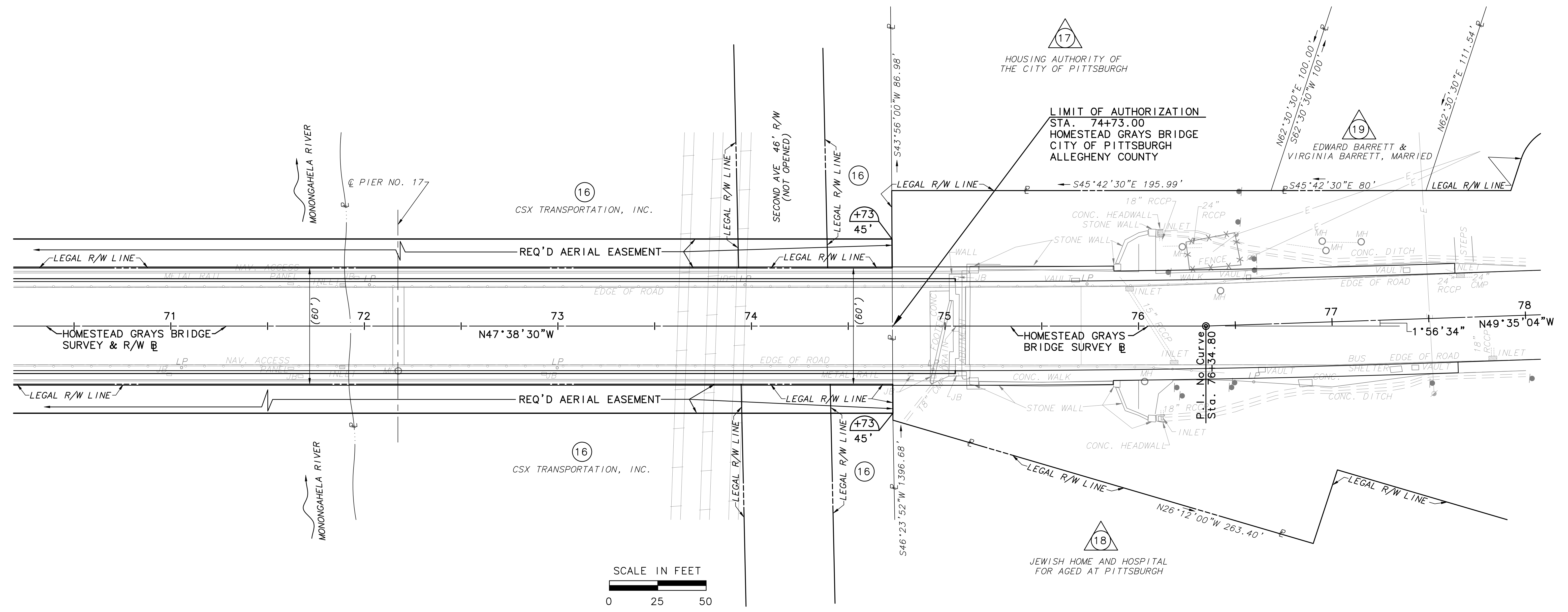

County of Allegheny Pittsburgh, Pennsylvania Department of Public Works	
RIGHT-OF-WAY PLAN HOMESTEAD GRAYS BRIDGE MA12 - 3513	
REVISIONS	
DRAWN BY: DSH/BPP	CHECKED BY: REP
DATE: 03-25-04	SCALE: AS SHOWN
CADD FILE: 2047PLA05.DWG	SHEET 8 OF 10
25965-RW	

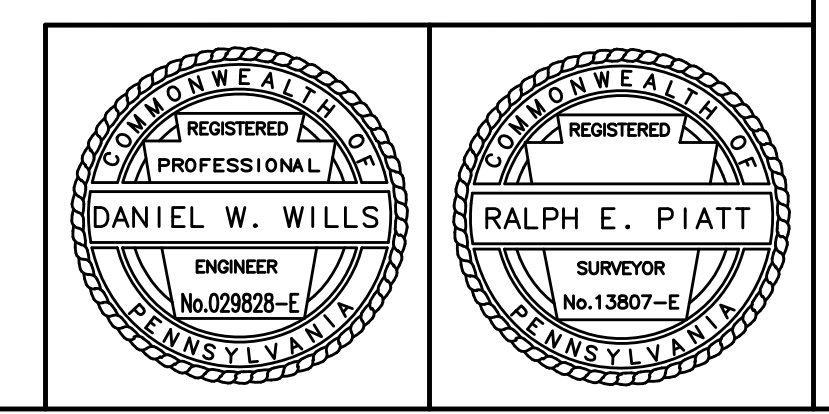

FOR AERIAL EASEMENT DEFINITION SEE SHEET 3 OF 10

FOR TABULATION OF PROPERTIES SEE SHEET 10 OF 10